

ENERGY

MANAGEMENT

PROGRAMS



**Helping members save money
and use electricity wisely.**

SERVING OUR MEMBERS

A hand holding a glowing lightbulb with a digital network overlay. The background is a blurred office setting with a person's face partially visible. The lightbulb is the central focus, emitting a warm glow and surrounded by a network of white dots and lines, symbolizing energy efficiency and technology.

ENERGYWISE PROGRAMS

SAVE ENERGY,

SAVE MONEY

The products and appliances you install in your home have two price tags: the price you pay when you buy the product, and the price you pay to operate it.

When you think about saving money, think about energy efficiency. By making smart choices in your home you can lower your energy bills.



SAVE WITH LOAD MANAGEMENT

Load management is an approach by which the peak demand of electric energy can be curtailed to allow better use of existing generating capacity. Lowering the peak benefits all members by reducing wholesale power cost. These savings are passed along to participating members through lower electricity rates.

Speak to an Itasca-Mantrap member services representative to see how you can start saving at your home.

TABLE OF CONTENTS

- 05** Home Heating
- 06** Dual Fuel
- 08** Heat Pumps
- 12** Off Peak
- 14** Off Peak Underfloor Install
- 15** Dual Fuel Underfloor Install
- 16** Storage Water Heating
- 17** Authorized Water Heater Dealers
- 19** Peak Shave Water Heating
- 20** Surge Protection
- 22** Electric Vehicles
- 24** Renewable Energy
- 26** Contractors

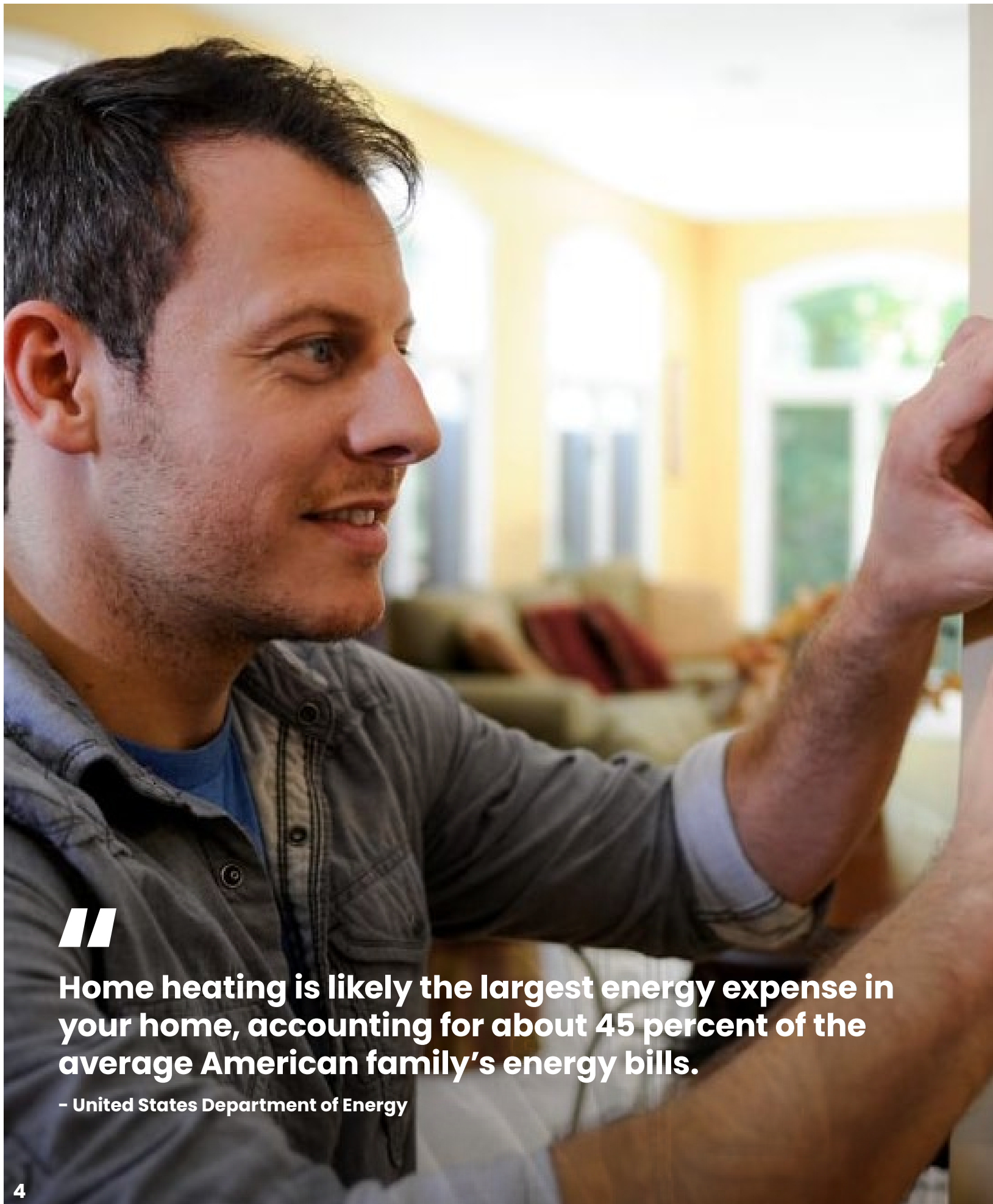

//

Home heating is likely the largest energy expense in your home, accounting for about 45 percent of the average American family's energy bills.

- United States Department of Energy



HOME HEATING

The cost of heating a home varies based on several factors, including the size of the home, heating fuel type, heating system efficiency, insulation of the home, and even how the home is used.

The chart below compares various heating system efficiencies and fuel types to Itasca-Mantrap's rates. As an example, if you have an 80% efficient propane boiler, you would need to purchase propane for less than \$1.12 to beat the Off Peak rate for electric heating.

COST COMPARISON

Heat Type	Electric		L.P. Gas		Fuel Oil	
Efficiency			92%	80%	80%	70%
Electric Resistance	100% Efficient	5.2¢	\$1.30	\$1.12	\$1.70	\$1.49
		rate	gal.	gal.	gal.	gal.
		6.77¢	\$1.68	\$1.45	\$2.20	\$1.92
		9.97¢	\$2.48	\$2.24	\$3.24	\$2.84
Air Source Heat Pump	250% efficient	6.77¢	\$0.67	\$0.58	\$0.88	\$0.77
		rate	gal.	gal.	gal.	gal.
		9.97¢	\$0.99	\$0.86	\$1.30	\$1.13
Ground Source Heat Pump	350% Efficient	6.77¢	\$0.48	\$0.42	\$0.63	\$0.55
		rate	gal.	gal.	gal.	gal.
		9.97¢	\$0.71	\$0.62	\$0.94	\$0.81

DUAL FUEL



The Dual Fuel program combines two heating sources to best fit your budget and tailor your energy investment to meet your heating needs.

Itasca-Mantrap's Dual Fuel program offers the option to incorporate a low-cost electric heat source with an alternate heating system.

In a Dual Fuel heating system, an electric heat source, such as baseboard heat, is used in conjunction with fuel oil, propane or electric storage heat as the back-up heating system.

How It Works:

Dual Fuel is a "controlled" electric heating program, which helps save money and conserve energy. When demand for electricity is high, the electric heat source is shut off, or controlled (up to a maximum of 400 hours per heating season) with a maximum continuous control time of 12 hours (usually 4 to 6 hours at a time). During control periods, your home's back-up heating system provides the heat you need.

Acceptable Back Up Heating Systems Include:

- Fuel Oil Furnace
- Fuel Oil Boiler
- Propane Furnace
- Propane Boiler
- Electric Thermal Storage

Signing up for the Dual Fuel program qualifies you to receive a reduced rate of \$0.068.



Dual Fuel Rebate
\$25 per kW installed

DUAL FUEL APPLICATIONS

There is a variety of equipment you can use in a Dual Fuel application. Here are a few examples of the type of electric heat equipment you can use.

PLENUM HEATER

An electric plenum heater is one of the most common dual fuel applications. It is placed into the duct work above an existing gas or fuel oil forced air system to provide electric heat to your home.

Plenum heaters come in a variety of sizes to fit most applications, and installation is generally easy. Also, equipment costs are competitive in comparison to other home heating options.

ELECTRIC BOILER

An electric boiler delivers heat through piping or tubing. In retrofit applications, it is installed in conjunction with the existing boiler. In new installations, it can be used for a quality radiant floor heating system.

ELECTRIC BASEBOARD

This option uses electric resistance heating and can be used in almost any application. The units are easy to maintain, clean, safe, have a long life and require no ducts.

AIR SOURCE HEAT PUMP

An air source heat pump is the best of both worlds, providing home cooling and supplemental heating with 72 percent less electricity than conventional air conditioners or furnaces. Switch between heating and cooling directly from a thermostat, putting you in complete control.

GROUND SOURCE HEAT PUMP

A ground source heat pump (GSHP) is one of the most efficient residential heating and cooling systems available, providing heating efficiencies 50- 70 percent higher than other heating systems. GSHP systems use the constant temperature of the earth to transfer heat to and from your home.



AIR SOURCE HEAT PUMPS

Air source heat pump (ASHP) systems can both heat and cool your home with the same unit, using refrigeration technology to transfer heat. The refrigeration system consists of a compressor and two coils made of copper tubing.

In the winter, the unit extracts the heat from outside, down to an average of 200 F and transfers it into your house to keep you warm.

In the summer, the process is reversed, and the unit removes heat from your home and releases it outdoors, keeping you cool.

ASHPs will need to be separately metered and controlled on a load management program. The heat pump will be cycled on and off in 15-minute intervals during high demand times in the summer, and controlled the same as dual fuel in the winter.

By allowing us to occasionally cycle the equipment, the kilowatt-hours used by your heat pump will be billed at a reduced rate. You may also qualify for a rebate if your heat pump is installed by a participating contractor.*

Air Source Heat Pump Rebates*

\$750 ≥ 14.3 SEER2 & ≥ 7.5 HSPF2

\$1000 ≥ 16.0 SEER2 & ≥ 8.1 HSPF2



*Must be separately metered and controlled and installed by a participating contractor. Rebate applications are available only through a participating contractor.

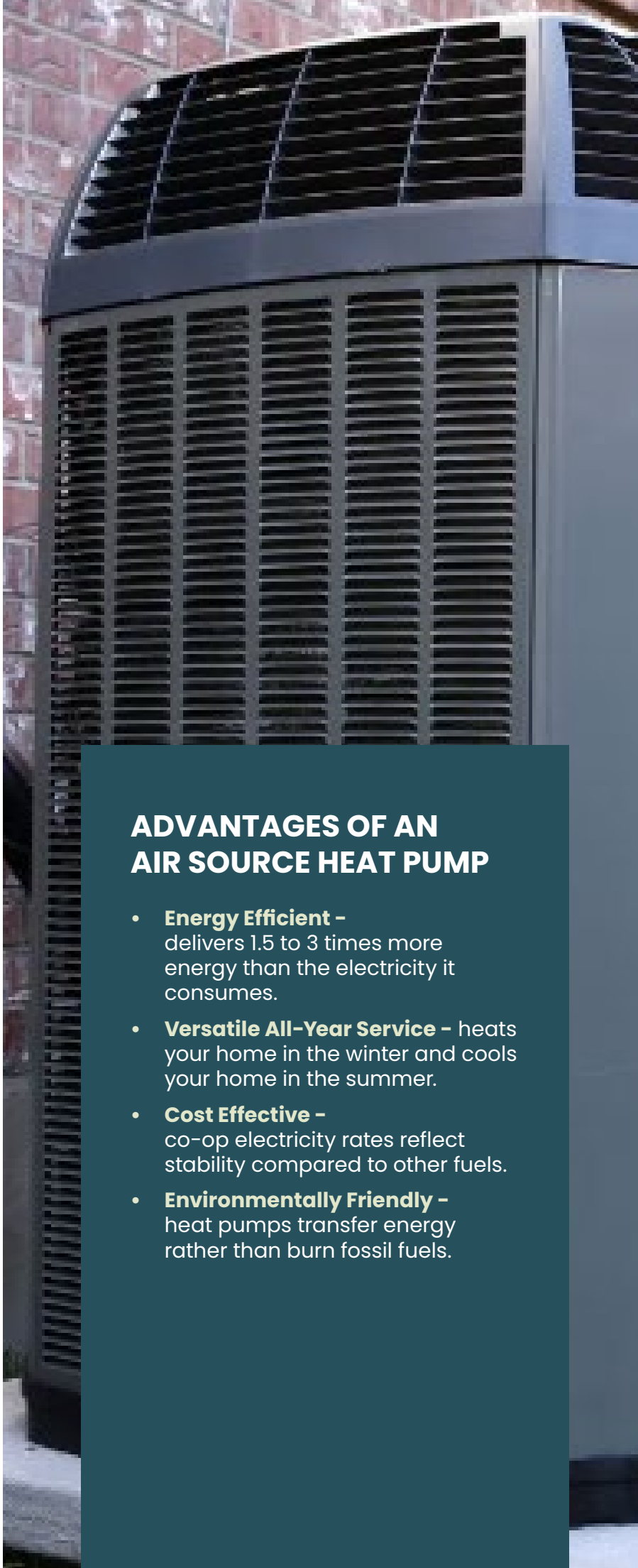

ADVANTAGES OF AN AIR SOURCE HEAT PUMP

- **Energy Efficient** - delivers 1.5 to 3 times more energy than the electricity it consumes.
- **Versatile All-Year Service** - heats your home in the winter and cools your home in the summer.
- **Cost Effective** - co-op electricity rates reflect stability compared to other fuels.
- **Environmentally Friendly** - heat pumps transfer energy rather than burn fossil fuels.



DUCTLESS AIR SOURCE HEAT PUMPS

Ductless air source heat pumps can be a good option for room additions and small spaces where extending or installing ductwork is not feasible.

Ductless air source heat pumps use 60 percent less energy than standard home electric resistance-based heating systems because they transfer instead of generate heat. These systems use sophisticated compressors and fans that can adjust speeds to save energy. Cut cooling costs by 30 percent compared to conventional room air conditioners.



Ductless Air Source Heat Pump Rebate

\$300 \leq 1-ton, \geq 14.3 SEER2 & \geq 7.5 HSPF2

\$750 $>$ 1-ton, \geq 14.3 SEER2 & \geq 7.5 HSPF2

\$1,000 $>$ 1-ton, \geq 16.0 SEER2 & \geq 8.0 HSPF2

GROUND SOURCE HEAT PUMPS

Ground source heat pump (GSHP) systems use the constant temperature of the earth to transfer heat to and from your home. This allows the system to reach efficiencies up to 300 to 500 percent.

In the heating mode, GSHP systems transfer heat through a vertical or horizontal loop system installed in the ground. Heat energy is carried into the home through piping connected to and powered by a heat exchange unit inside the home. In the summer this process is reversed to transfer heat from the home into the ground.

While Minnesota experiences seasonal temperature extremes, a few feet below the earth's surface the ground remains at a relatively constant temperature. This ground temperature is warmer than the air above it during the winter and cooler than the air in the summer. The GSHP takes advantage of this by exchanging heat with the earth through the ground heat exchanger.

Even though the installation price of a GSHP can be several times that of an air source system, the additional costs are returned to you in energy savings in five to ten years. System life is estimated at 25 years for the inside components and 50 plus years for the ground loop.

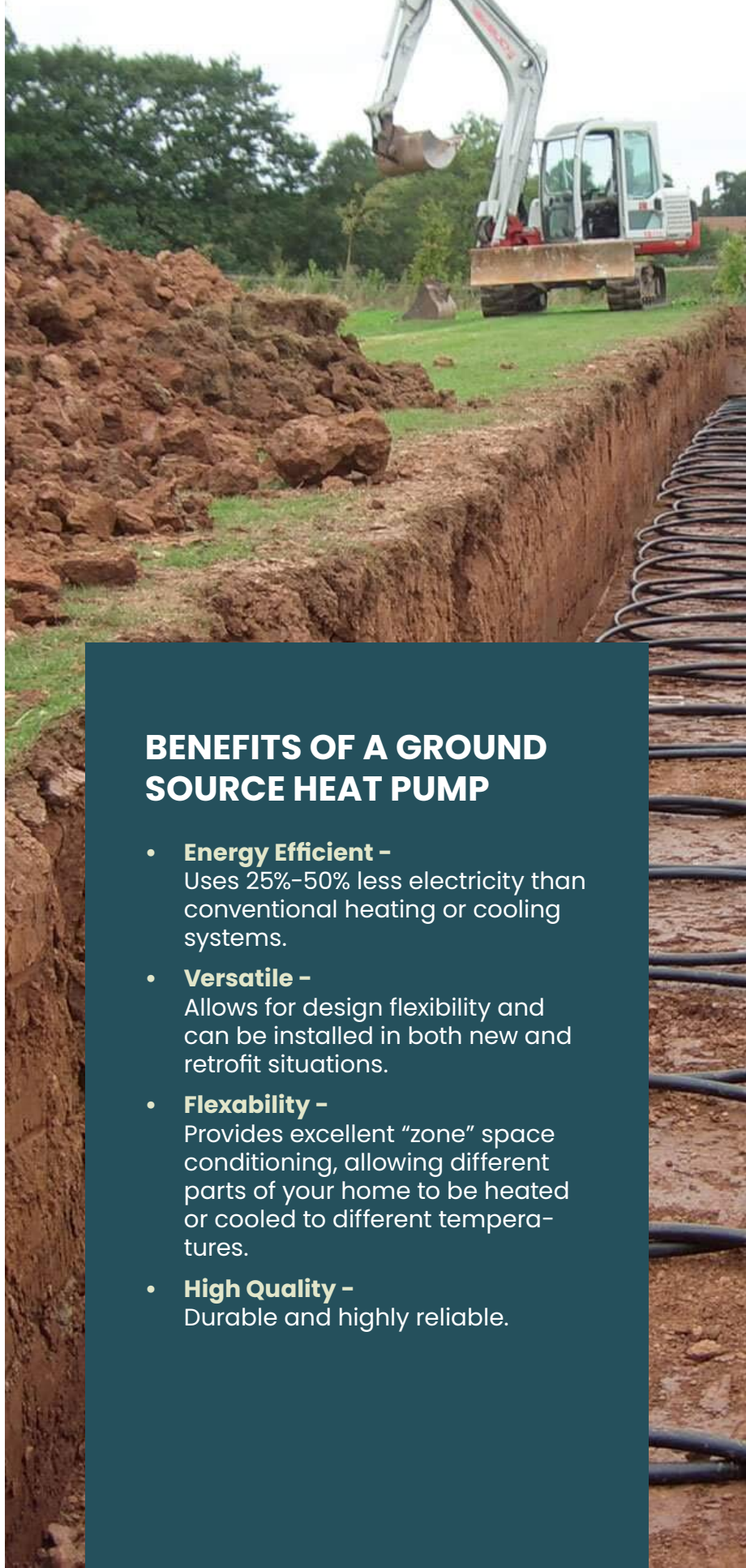

BENEFITS OF A GROUND SOURCE HEAT PUMP

- **Energy Efficient -**
Uses 25%-50% less electricity than conventional heating or cooling systems.
- **Versatile -**
Allows for design flexibility and can be installed in both new and retrofit situations.
- **Flexibility -**
Provides excellent "zone" space conditioning, allowing different parts of your home to be heated or cooled to different temperatures.
- **High Quality -**
Durable and highly reliable.



Ground Source Heat Pump Rebate
\$400 per ton



VERTICAL CLOSED LOOP SYSTEM

Vertical loops are used in commercial applications and in residential applications where the soil is too shallow for trenching and to minimize the disturbance to existing landscaping. Holes are drilled up to 400 feet deep. Two pipes are placed in the holes.



HORIZONTAL CLOSED LOOP SYSTEM

Horizontal loops are used in new construction where sufficient land is available. Two pipes are trenched in at least four feet deep. Looping the pipe allows for more pipe in a shorter trench, which cuts down on installation costs and makes horizontal installation possible in areas it would not be with conventional horizontal applications.



OFF PEAK HEATING

SAVE MONEY WHILE YOU SLEEP

Electric thermal storage (ETS) heating systems use off peak energy by storing enough heat during the night, when demand for energy is low, to heat the home throughout the day. The classic law of supply and demand applied to electric utilities results in much lower electric rates during the night, and we pass this savings on to our members through a special off-peak rate.

The off-peak rate is 5.3¢ per kilowatt-hour. Although the original purchase price of ETS home heating systems may be higher than many conventional heating systems, ETS produces substantial savings due to lower energy and maintenance costs over the life of the equipment.

Common Systems Include:

- Under-slab electric cable or water piping
- Individual room unit heaters
- Central storage forced-air furnace
- Central storage hydronic furnaces

Keep every room warm and cozy with 100 percent efficient storage heat. From 10 p.m. to 6 a.m. your storage heating system will charge. This stored heat will then heat your home all day long.



Off Peak Rebate
\$100 per kWh installed



STEFFES OFF-PEAK PRODUCTS

A Steffes ETS system contains electric heating elements which lie within special, high-density ceramic bricks. These bricks are capable of storing vast amounts of heat for extended periods of time. During Itasca-Mantrap's off peak hours, the elements generate heat that will be stored in the bricks. When heat is needed, the stored heat is automatically released into your home. Homeowners receive comfortable, even room temperatures, from floor to ceiling. It's very quiet, and can provide enough heat for a home of any size.

With off-peak heating systems, you never need to worry about:

- Purchasing propane, gas or other fuel
- Having a combustible fuel in your home
- Buying and maintaining a fuel tank
- Heat lost through a chimney

STEFFES HEATING SYSTEMS:



ETS HEATING FOR DUCTED APPLICATIONS

The Comfort Plus unit is designed to be the main heating system, and can be used as a stand alone furnace or installed with a heat pump to realize even greater efficiency and energy savings



ETS HEATING FOR HYDRONIC/ DUCTED APPLICATIONS

The Comfort Plus Hydronic system adds a new dimension to heating by blending hydronic heating with ETS technology. Through the use of a heat exchanger, this stored heat is transferred as needed from the storage media to a water or glycol solution, which is circulated to areas where the heat is needed.

ETS ROOM UNITS



Room units are non-ducted heaters which are designed to heat the room or area where they are placed. These heaters can be used in new construction applications, as a retrofit, or supplement to an existing heating system. The equipment is easy to operate and requires very little maintenance.

Off-Peak underfloor application

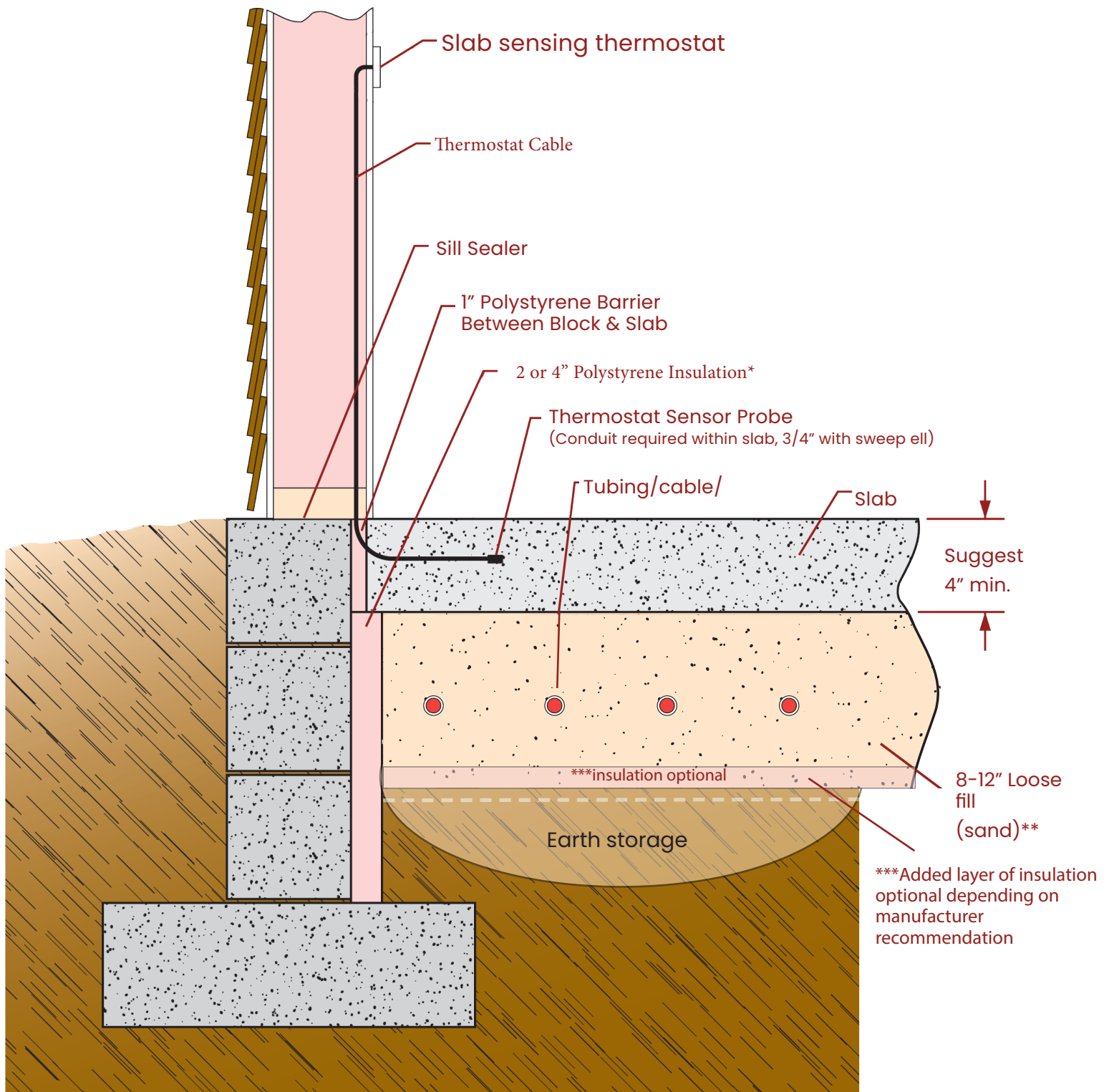

*At least 8-12" of loose fill is required for a storage application. If your application is not properly installed you may not have enough stored heat on the coldest winter days, and may need to change to a different program. Please discuss your planned application with Itasca-Mantrap and your electrical contractor before install to ensure you will be eligible for the Off-Peak program.

Dual Fuel underfloor application

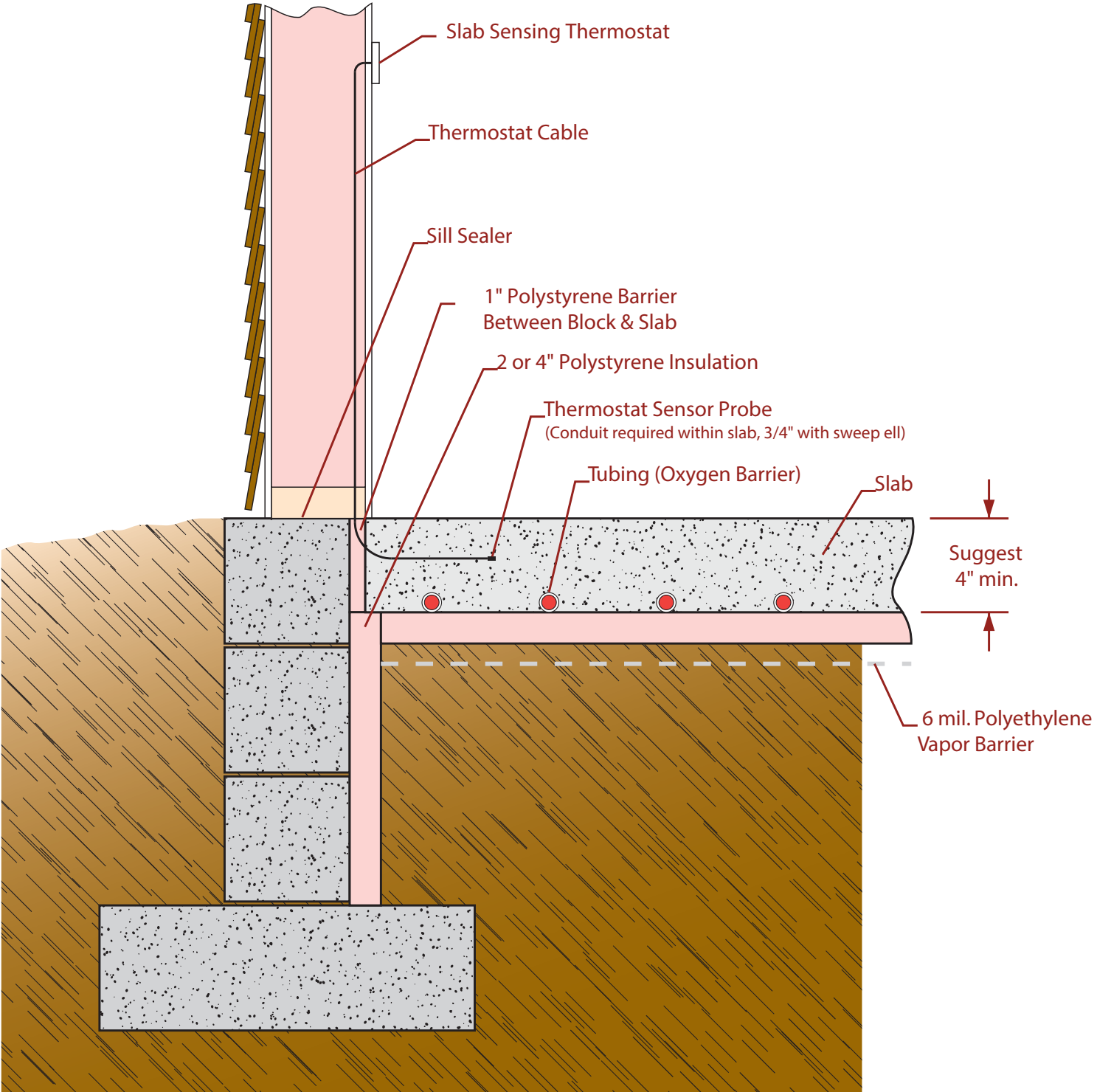

STORAGE

WATER

HEATING



The Electric Thermal Storage (ETS) water heating program encourages energy and water conservation. This program conserves energy by heating water during off-peak hours when electric costs are their lowest, typically from 10 p.m. to 6 a.m. The water heater stores enough hot water during that time to provide for your household for the remainder of the day.

Members who participate in the storage water heating program receive a reduced rate of \$0.053 per kilowatt-hours (kWh) used by the water heater.

All households have differing hot water needs, water heaters must be sized according to your specific needs.

01 ETS Control Water Heating - Separately Metered

- Minimum 100-gallon electric water heater
- \$600 rebate
- Contractor installs separate panel wired to separate meter
- \$0.053 per kWh - year round
- 16 hours of control per day

02 ETS Water Heating - General Service

- Minimum 100-gallon electric water heater
- \$600 rebate
- \$0.12 per kWh June-Aug., \$0.10 per kWh other months
- 16 hours of control per day
- \$5 credit/month applied to account
- Home must use 400 kWh per month to qualify for credit



Storage Water Heating Rebate*
\$600



HTP WATER HEATERS

- Stainless Steel Tank
- Titanium Elements for Corrosion Resistance
- Heavy Duty Foam Insulation

Sizing Options:

- 50 gallon
- 80 gallon
- 100 gallon

Lifetime warranty with online registration, 10 year warranty without registration.

Contact a contractor from the list below for pricing and more information.

AUTHORIZED WATER HEATER DEALERS

Contractor	Location	Contact
Ackerman Plumbing & Heating	Park Rapids, MN	218-732-7836
Brogard Plumbing, Heating & Excavating, Inc.	Henning, MN	218-583-2041
Ellenson Heating & Cooling	Park Rapids, MN	218-237-1152
Hass Geosystems, Inc.	Frazee, MN	218-538-6698
Ikes Heating and Cooling	Nevis, MN	218-652-4057
Leading Edge Mechanical, Inc.	Park Rapids, MN	218-237-5125
Lindow Plumbing	Nevis, MN	218-252-1900
Lindy's Plumbing, LLC	Benedict, MN	218-224-2274
Lowe Electric	Akeley, MN	218-547-3929
Millard Plumbing & Heating	Walker, MN	218-836-3000
Modern Heating and Plumbing, Inc.	Detroit Lakes, MN	218-847-7459
Northern Pines Plumbing & Heating	Park Rapids, MN	218-732-5845
Park Rapids Plumbing and Heating	Park Rapids, MN	218-732-7238
R&G Plumbing & Heating, Inc.	Osage, MN	218-252-1510 or 255-0227
Samuelson Laney Plumbing & Heating	Park Rapids, MN	218-237-9276
T & T Plumbing & Heating	Menahga, MN	218-564-5324
Ulvin Plumbing & Heating	Park Rapids, MN	218-732-0026
Retail		
Cwilka Ace Hardware	Park Rapids	218-732-4513



Water heating accounts for about 18% of your home's energy use and is typically the second largest energy expense in any home.

- United States Department of Energy

PEAK SHAVE

WATER HEATING

The Peak Shave water heating program is designed to reduce demand on the electrical system on days of high demand and high wholesale energy prices ultimately helping to keep energy rates low. Water heaters enrolled on this program can be controlled for up to 8 hours on peak days. Water heaters must have sufficient storage capacity to supply hot water over a peak period.

Members who participate in the peak shave water heating program receive a reduced rate of \$0.068 per kWh used by the water heater.

01 Peak Shave Water Heating - Separately Metered

- Minimum 50-gallon electric water heater
- \$300 rebate*
- \$0.068 per kWh - year round
- Up to 8 hours of control during peak periods
- Contractor installs separate panel wired to separate meter

02 Peak Shave Water Heating - General Service

- Minimum 50 gallon electric water heater
- \$300 rebate*
- \$0.12 per kWh June-Aug., \$0.10 per kWh other months
- Up to 8 hours of control during peak periods
- \$3 credit/month applied to account
- Home must use 400 kWh per month to qualify for credit



Peak Shave Water Heating Rebate*

\$300

*Installed water heaters must have an energy factor of .90 or higher and have a combined capacity of at least 50 gallons to qualify.



SURGE

PROTECTION

Surge suppression equipment protects your electronic devices and appliances from lightning damage and other potential power surges.

JUST A SECOND...

That's all it takes for lightning to strike and cost you thousands of dollars in damage to your electronic devices and appliances: computers - garage door openers - refrigerators - TVs - satellite receivers - washing machines - stereos - fax machines - phones - and more.

Each year, power surges resulting from lightning cause an estimated \$500 million in damage to electronics - most of which could have been avoided with proper surge protection.

ARE YOU PREPARED?

Anyone who has electronic appliances should consider some level of surge suppression equipment. There is point-of-use equipment designed to protect specific appliances as well as equipment to protect your whole house.

WHOLE HOUSE SURGE PROTECTION

Recommended to protect large “white” appliances such as your refrigerator, washer, dryer and electric range. A meter-based surge protection system can be rented monthly from Itasca-Mantrap or you can purchase a panel-based system from an electrical contractor who would wire the device to your panel. Make sure the surge protection device comes with a connected equipment warranty to cover your appliances.

METER-BASED SURGE PROTECTION SYSTEM

A meter-based surge protection system is designed for installation at the electrical meter socket to provide high level, whole house surge protection. This system can be rented from Itasca-Mantrap, speak to a member service representative for more information.



SEPARATE POINT-OF-USE PLUG-IN PROTECTION

Recommended for equipment such as your television, computer and phones. Options range from a standard one-outlet surge protector to large multi-outlet devices with coaxial cable and phone attachments. Some units come with an Uninterruptible Power Supply (UPS) for uses requiring battery backup. This equipment can be purchased online or at various retailers. Make sure the surge protection device comes with a connected equipment warranty to cover your sensitive electronic equipment.

ELECTRIC VEHICLES



TYPES OF ELECTRIC VEHICLES

If you're looking to purchase an electric vehicle, use this cheat sheet to help determine the various options. Drivers can choose between three types of electric vehicles (EVs). EVs are classed by the amount of electricity that is used as their energy source.

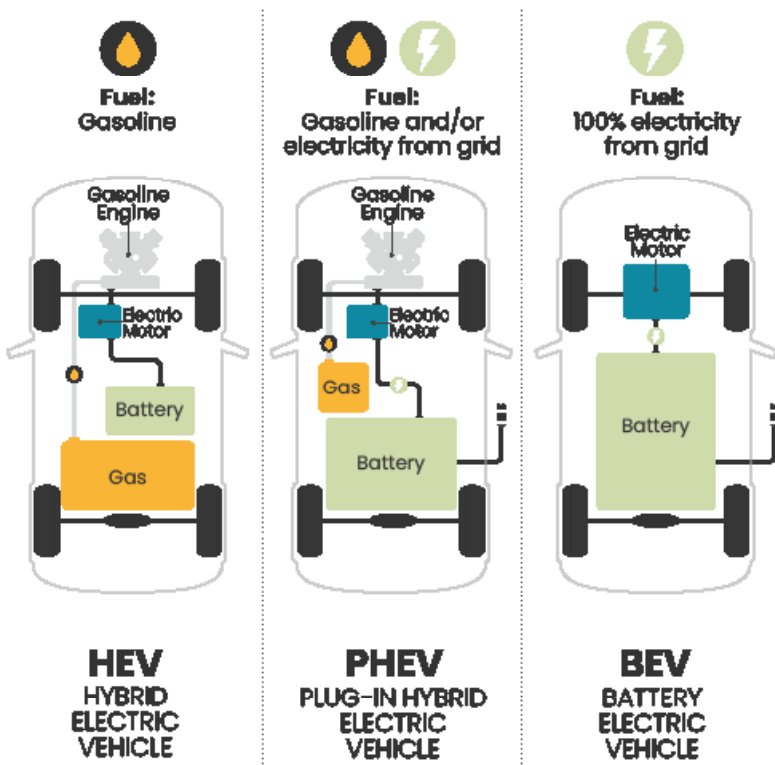

POWER YOUR ELECTRIC VEHICLE (EV) WITH 100% WIND ENERGY.

With our power supplier, Great River Energy, we're offering you an opportunity to power your EV with 100% wind energy, for the lifetime of that vehicle, at no extra cost. You'll still have to pay for the energy you use, but you'll be able to do so knowing that when you go electric, you'll always be going green.

HOW DO YOU KNOW YOU'LL BE GETTING 100% WIND ENERGY?

Energy comes from all kinds of sources; wind, natural gas, coal and so on. Once it hits the power grid, there's no way of telling where it came from. However, when renewable energy is added to the mix, a renewable energy credit (REC) is created that embodies all of the environmental benefits of that energy. When you claim your Revolt upgrade, we'll dedicate wind energy RECs on your behalf, completely off setting the energy used to power your EV.

Ask an Itasca-Mantrap member service representative for more information about the Revolt EV program.

Itasca-Mantrap offers two voluntary options for charging your EV at home. The off-peak program offers the lowest price, while the whole house time-of-use program provides flexibility.

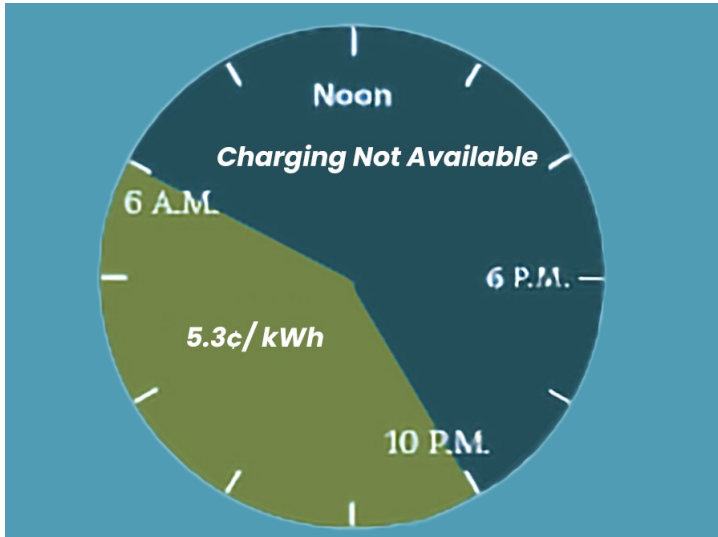

Off-Peak Rate

Itasca-Mantrap's off-peak rate offers members low cost electricity for charging an EV. Electricity for charging your EV is available only during the off-peak hours of 11 p.m. to 7 a.m. Power will not be supplied outside of the off-peak hours and the charger or outlet must be hardwired into your circuit panel.

This program requires a separate meter. Itasca-Mantrap offers a rebate of up to \$500 to cover the cost of installing a charger on the off-peak program.

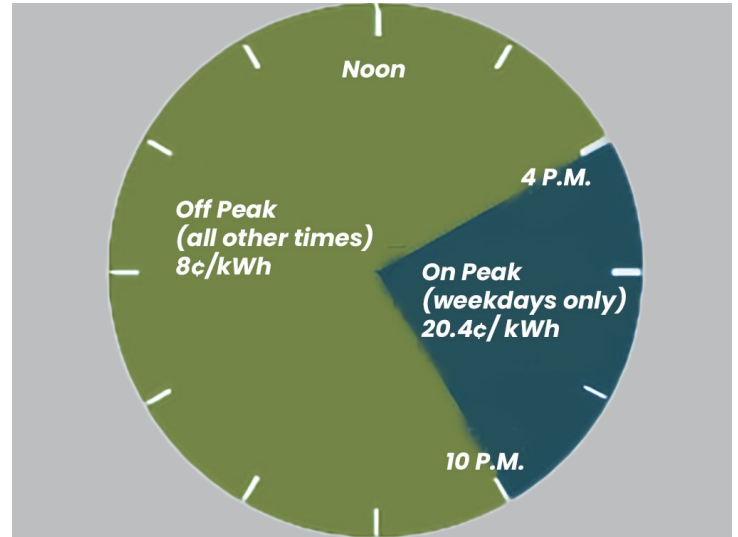

Whole House Time-of-Use Rate

A charger or outlet installed on the Itasca-Mantrap whole house time of use rate will always receive electricity, so you can charge your vehicle whenever you need. You pay the rate listed for all the electricity you use throughout your home, according to the time-of-day. The savings can add up when you make the choice to use energy at different times of day.



RENEWABLE ENERGY



WIND POWER

Wellspring® Wind Energy is a voluntary, subscriber-based renewable energy program offered through Great River Energy, Itasca-Mantrap's wholesale power supplier.

For every contribution, additional renewable energy is purchased through the Wellspring Wind Energy program. Since wind energy is more expensive than traditional generation sources, Members electing to participate in the program pay an additional amount on their electric bill.

- An average home uses 800 - 1,000 kilowatt-hours (kWh) of electricity per month
- Itasca-Mantrap members can purchase Wellspring Wind Energy in 100-kWh blocks
- Each 100-kWh block is \$1.50, the dollar amount selected will be added to your monthly bill
- If you wish to enroll in the Wellspring Wind Energy program, speak to an Itasca-Mantrap member service representative.



SOLAR POWER

SolarWise is a community-based solar array designed to make it easy and affordable for our members to utilize an alternative energy option.

The Itasca-Mantrap SolarWise Community Solar array consists of 112 panels, 46 kilowatts total, made and installed by Minnesota based company, tenKsolar. The community solar project was completed and went live in 2015.

HOW COMMUNITY SOLAR WORKS

The Itasca-Mantrap Community Solar project allows members to purchase a portion of the output of the kilowatt hours generated from a centrally located photovoltaic system. The solar panels are installed on the Cooperative's property and members purchase shares of the system production in the form of one or more solar panels. Members are then credited on their monthly bill based on their portion of the system production. With SolarWise, we've taken care of the cost of installation, maintenance and insurance fees, making it easy for you to participate.

HOW YOU CAN PARTICIPATE

Members can purchase output up to 80 percent of their average general service energy use for 16 years or five years. A no-interest payment plan is also available. The cost includes insurance, operations, maintenance and all other costs associated with operating the solar array. For seasonal members, credits apply towards the basic charge in the winter months.

The panels are currently sold out, but we are taking names for those interested in participating in the future! Contact us to get your name on the waiting list!



CONTRACTORS

PLUMBING AND HVAC CONTRACTORS

Contractor	Location	Contact
Ackerman Plumbing & Heating ^*	Park Rapids	218-732-7836
Advantage Heating & Cooling^*	Backus	218-947-4480
AJ's Heating & Cooling^A	Laporte	218-368-5617
Blubird Services LLC^A	Menahga	218-255-9848
Christensen's Heating & Cooling^A	Menahga	218-255-0165
Denny's Plumbing, Heating and A/C, LLC	Nevis	218-652-2016
DMP Heating and Cooling, LLC^*	Menahga	218-564-5654
Ellenson Heating & Cooling^A	Park Rapids	237-1152/218-252-4775
Graham HVAC^A	Solway	218-556-0597
Ikes Heating and Cooling^*	Nevis	218-652-4057
Keefe Heating, AC & Climate Control^A	Backus	218-947-3210
Leading Edge Mechanical, Inc.^A	Park Rapids	218-237-5125
Lindow Plumbing	Nevis	218-252-1900
Naylor's Heating & Refrigeration^A	Bemidji	218-444-4328
North Country Electrical Services	Benedict	218-224-2704
North Star Service	Benedict	224-3130/888-955-1918
Northern Pines Plumbing & Heating^*	Park Rapids	218-732-5845
Park Rapids Plumbing and Heating^*	Park Rapids	218-732-7238
Peterson Sheet Metal	Bemidji	218-751-4502
R&G Plumbing and Heating, Inc.^A	Osage	218-252-1510/255-0227
Service Professionals^A	Wadena	218-631-2638
Samuelson Laney Plumbing & Heating^*	Park Rapids	218-237-9276
True North Mechanical^A	Park Rapids	218-252-4877
Ulvin Plumbing & Heating^A	Park Rapids	218-732-0026
Wroolie Refrigeration Heating and Cooling^A	Akeley	320-493-3214

GROUND SOURCE HEAT PUMP CONTRACTORS

Contractor	Location	Contact
Ackerman Plumbing & Heating	Park Rapids	218-732-7863
Ikes Heating and Cooling^*	Nevis	218-652-4065
Keefe Heating, AC & Climate Control^A	Backus	877-271-0970
Mid Valley	Ottertail	701-847-3031/800-763-5196
North Country Electrical Services	Benedict	218-224-2704
Northern Pines Plumbing & Heating	Park Rapids	218-732-5845
Peterson Sheet Metal	Bemidji	218-751-4502
Ulvin Plumbing & Heating^A	Park Rapids	218-732-0026

^Certified for Air Source Heat Pump *Steffes Certified Dealer

ELECTRICAL CONTRACTORS

Contractor	Location	Contact
ACE Electric	Park Rapids	218-732-8467
Armory Electric*	Park Rapids	218-732-0456
Avenson Electric*	Park Rapids	218-252-9350
Bergstrom Electric*	Park Rapids	218-732-8304
Bessler Brothers	Lake George	218-699-3901 218- 224-2472
Brent Electric	Park Rapids	218-732-5935
B&M Electric	Detroit Lakes	218-847-1946
Dailey Electric	Sebeka	218-632-5957
Davidson Electric	Ogema	218-983-3209
DELCO Electric	Menahga	218-252-1771
Fraze Electric*	Fraze/Park Rapids	218-334-2382
Hansen's Electric, Inc.*	Park Rapids	218-732-3818
Hoffman Electric	Park Rapids	218-732-8374
Kopkie Electric, LLC	Park Rapids	218-255-3100
Levi Durgin Electric	Nevis	763-355-4291
Longfors Electric	Detroit Lakes	218-846-1252
Marchell Electric*	Park Rapids	218-732-8862
Northern Pines Electric	Park Rapids	218-732-5845
Olson Electric	Walker	218-547-1320
Steve's Electric*	Park Rapids	218-732-3340
Todavich Electric	Bemidji	218-751-1699
Chuck Trosen*	Walker	218-675-5757
Zenergy	Sebeka	218-837-5155

ELECTRICAL INSPECTORS – STATE BOARD OF ELECTRICITY

Hubbard County	Anthony Kohrs: 612-770-1938
Becker County	Andy Bozovsky: 218-340-0926
Cass County: Birch Lake, Deerfield, Hiram, Shingobee Townships	Anthony Kohrs: 612-770-1938
Cass County: Bull Moose Township	Michael Wenzel: 218-270-2265
Wadena County	Adam Sorensen: 320-304-3927

Electrical Inspectors take calls between 7:00 a.m. and 8:30 p.m.



ITASCA-MANTRAP ELECTRIC COOPERATIVE



ITASCA-MANTRAP ELECTRIC COOPERATIVE
PO Box 192, Park Rapids, MN 56470
218-732-3377 | 888-713-3377 | www.itasca-mantrap.com